



Tutorial: modeling an electron lens with SolidWorks

Stanley Humphries, Copyright 2012

Field Precision

PO Box 13595, Albuquerque, NM 87192 U.S.A.

Telephone: +1-505-220-3975

Fax: +1-617-752-9077

E mail: techinfo@fieldp.com

Internet: <http://www.fieldp.com>

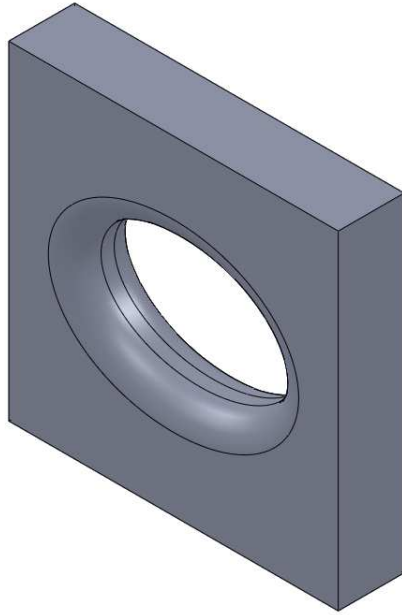

Figure 1: Einzel lens electrode with elliptical aperture.

MetaMesh (the mesh generator for our three-dimensional programs), supports the direct input of complex objects from **SolidWorks** and other CAD programs. This tutorial illustrates the effective use of **SolidWorks** objects in **MetaMesh** assemblies. It gives a step-by-step description of the procedure for people who may not use **SolidWorks** every day. The program has almost infinite capabilities – I will review a simple part that might appear in an electron optics system. My motivation was a recent consulting project, simulation of a three-dimensional electron beam transformation by an einzel lens. For a beam that propagates in z , the electrostatic lens achieves different focal properties in x and y through the use of an elliptical aperture in the central electrode (Fig. 1).

Using the native solid models of **MetaMesh**, it is possible to create a plate with an elliptical hole. The process would leave sharp edges, and one of the purposes of the study was to ensure that peak electric field levels were sufficiently low. Putting a uniform fillet around an elliptical opening is beyond the capabilities of the basic **MetaMesh** shapes, but is relatively easy in **SolidWorks**.

My strategy was to build other parts of the transport system from basic solids and to create the central electrode in **SolidWorks**. The part could then be ported to **MetaMesh** as an **STL** file. In the study, I needed to position the electrode to optimize beam focusing. In this case, it is more convenient to use the **SHIFT** command of **MetaMesh** rather than to regenerate the **SolidWorks** model and to export a new **STL** file. Accordingly, I

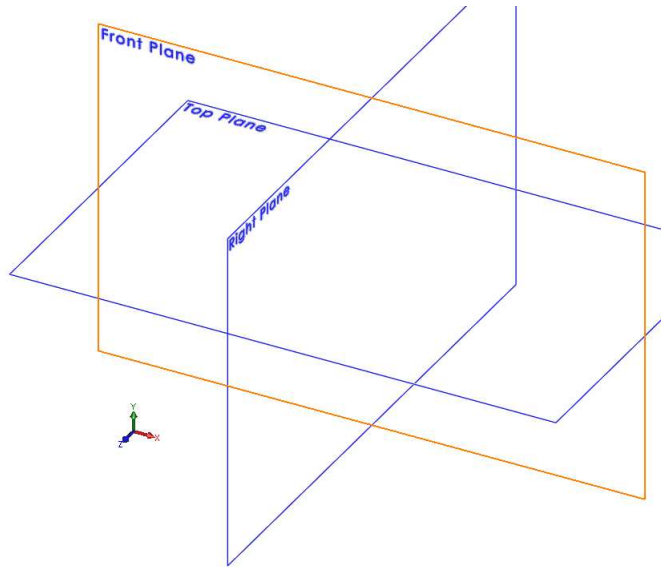

Figure 2: Pick a plane for making a sketch

creates a **SolidWorks Part** (rather than an *Assembly*) centered at $x = 0.0$ mm, $y = 0.0$ mm and $z = 0.0$ mm. The choice corresponds to the workbench space of **MetaMesh**. I then moved the part to an absolute position in z . In this tutorial, we shall fabricate a plate with dimension $L_x = 50.0$ mm, $L_y = 50.0$ mm and $L_z = 10.0$ mm. The elliptical hole has dimensions $R_x = 15.0$ mm and $R_y = 10.0$ mm.

Run **SolidWorks** and set dimensions to mm. For this, choose the menu command *Tools/Options/Document properties/Units* and activate the radio button **MMGS**. Next, click *File/New*. Choose the *Part* option in the dialog. A good practice is to save the work often, so choose *File/Save* and supply the name `central_electrode`.

To get started, click the tool *Extruded boss/base*. We will make sketches in the x - y plane to define the cross-sections of the plate and the aperture. Therefore, move the mouse to pick the *Front* plane (normal to z) as in Fig. 2. The program enters sketch mode. Pick the tool *Center rectangle* and move the cursor over the intersection of the red arrows (the origin) until it becomes active (Fig. 3). Click the left button and then move the mouse to define a rectangle of any dimension. Accept the operation by clicking the green check symbol on the left side of the screen. Next we will set the exact dimensions of the plate. Use the mouse to pick the top side of the rectangle (Fig. 4). In the *Line properties* section of the left, set the length dimension to 50.0 mm. Do the same for the left side. Click *Zoom to fit* for a better view.

We are now ready to use the sketch to create a solid plate. Click on *Exit sketch*. The information area on the left side is ready for instructions to make

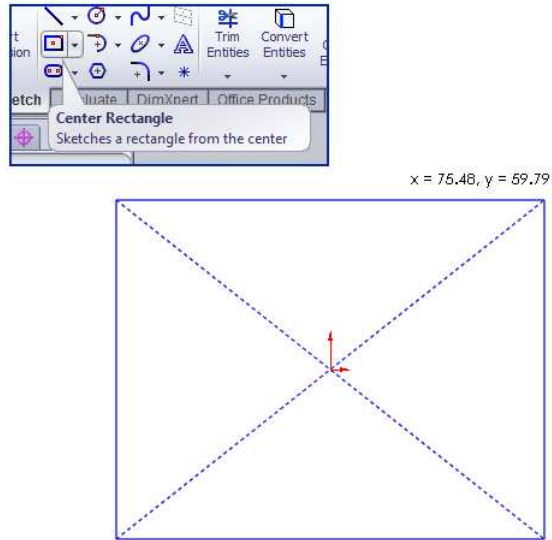

Figure 3: Add a centered rectangle.

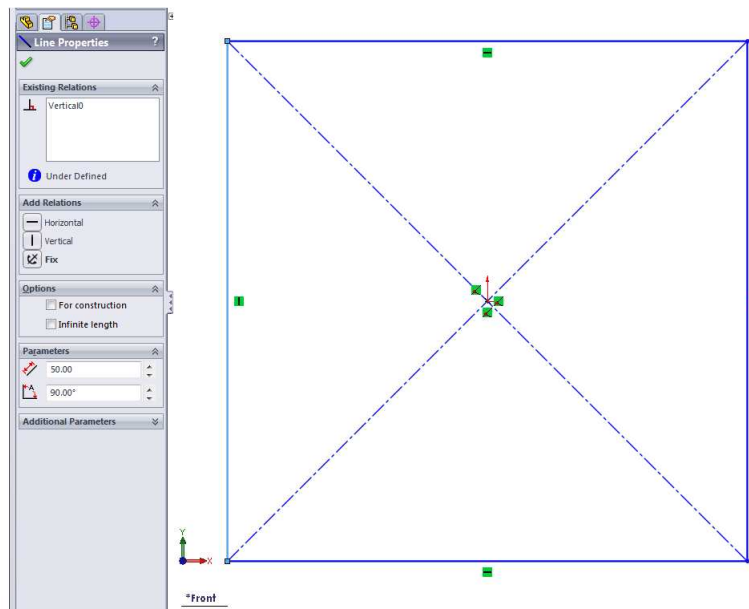

Figure 4: Set the width of the rectangle.

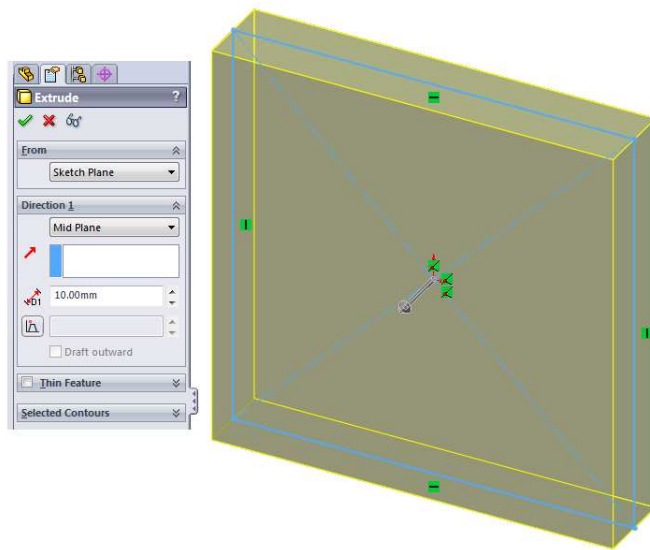

Figure 5: Extrusion of the sketch to create the plate.

the extrusion. Under *Direction 1*, choose the option *Midplane* in the list box. Fill in 10.0 mm for the depth. The result is a plate that extends between $-5.0 \leq z \leq 5.0$ mm. Click the green check symbol to add the part. This may be a good time to save the work.

The next step is to add the elliptical hole. Use the mouse to choose the front face of the plate (Fig. 6). It will be highlighted in blue. View the solid from the front face and click on the sketch tab. Pick the *Ellipse* tool and again associate the center point with the coordinate origin in the x - y Move the mouse until the origin is highlighted and click the left button. Then move the mouse and click the left button to set any width in x and then set a width in y . We can set the exact dimensions in the information box on the left. Both the x and y angles should be 0.0° . Fill in the dimensions $R_x = 15.0$ mm and $R_y = 10.0$ mm and then click the green check mark. Finally, we extend the elliptical hole through the plate. Exit the sketch mode, choose the sketch with the mouse and click on the *Extruded cut* tool. Use the option *Through all*. The final operation is to add fillets to the edges of the aperture. Under *View orientation*, pick *Isometric*. Both edges of the aperture should be visible. Use the mouse to pick the front edge and then click the *Fillet* tool. In the information box, set the fillet radius to 4.0 mm. Pick the rear edge and add another 4.0 mm fillet. Figure 1 shows the finished part.

After saving the work, we save the part as an STL file. Click *File/Save as*. In the *Type* list box choose STL. Then click *Options* to show the dialog of Fig. 8. There are several choices to make:

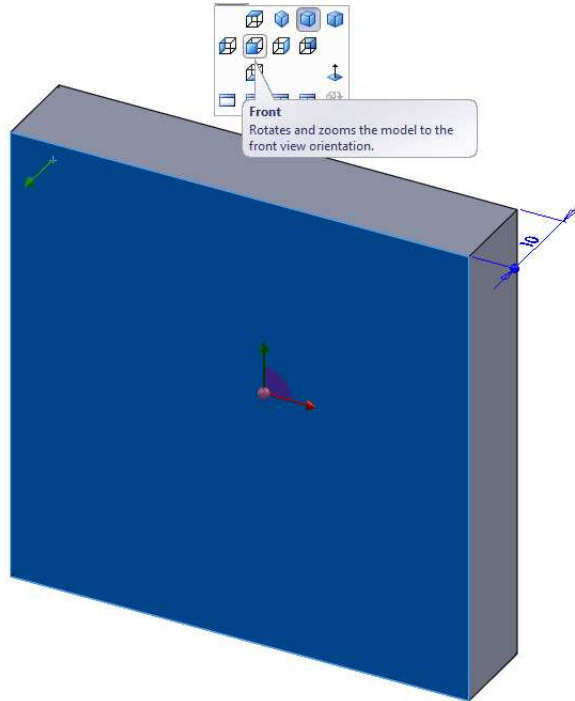

Figure 6: Pick the front face of the plate to make a sketch of the aperture.

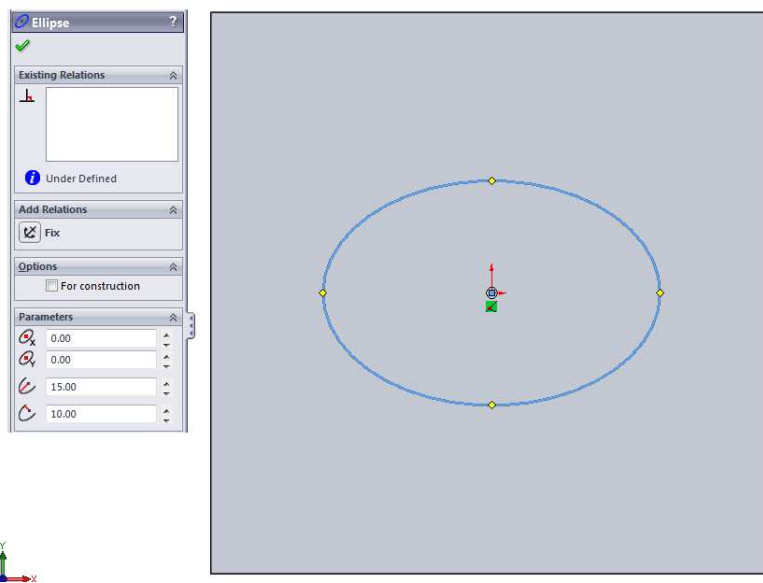

Figure 7: Make a centered ellipse.

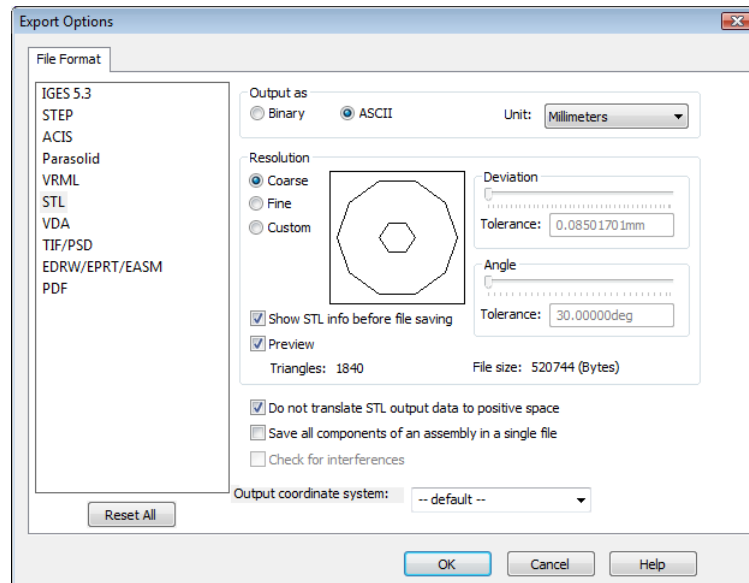

Figure 8: Export options dialog.

- An ASCII format file is larger, but is more transparent in case there is a problem. You can inspect it with a text editor.
- Set the units to mm.
- There is no advantage to use facets that are much smaller than the **MetaMesh** element size. Generally, the choice of *Coarse* is sufficient. An unnecessarily high resolution will increase the **MetaMesh** run time and the chance of an error.
- Be sure to check the box *Do not translate STL output data to positive space* to preserve the chosen part coordinates.

You can check the file using the **Geometer** *STL Viewer*. Figure 9 shows the tessellation of the solid surface created by **SolidWorks**. The facet perspective plot was created by unchecking the *Solid* box in the *Region display* dialog. The resolution of the filleted edges is clearly sufficient for electrostatic calculations.

We can use **Geometer** to create a quick **MetaMesh** script to observe how the shape appears in a conformal hexahedron mesh. Table 1 shows an example, which illustrates how to load an STL object. Figure 10 shows the end result.

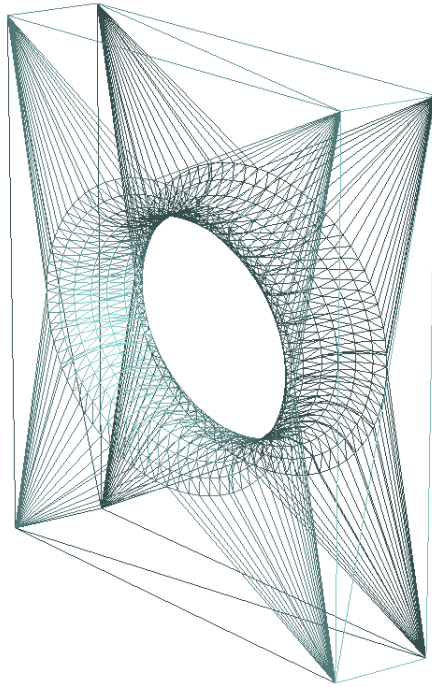

Figure 9: Facets in the STL file displayed by the **Geometer** *STL Viewer*.

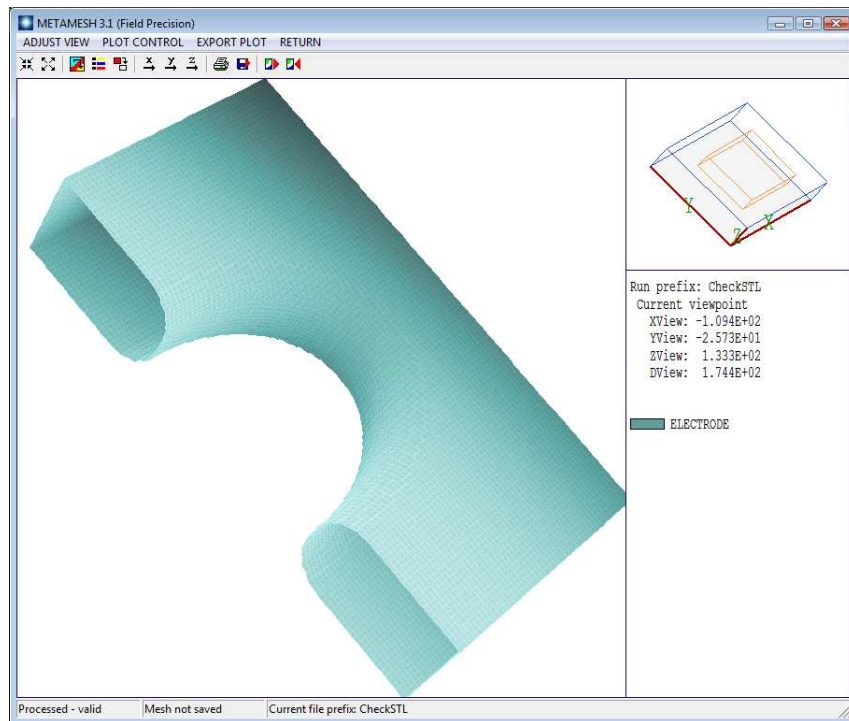

Figure 10: Cutaway view of the electrode in the hexahedron mesh created by **MetaMesh**.

Table 1: **MetaMesh** script CheckSTL.MIN.

```
GLOBAL
  XMesh
    -30.0 30.0 0.50
  End
  YMesh
    -30.0 30.0 0.50
  End
  ZMesh
    -10.0 10.0 0.50
  End
  RegName(1): SolutionVolume
  RegName(2): Electrode
  Parallel
END

PART
  Region: SolutionVolume
  Name: SolutionVolume
  Type: Box
  Fab: 60.0 60.0 20.0
END

PART
  Region: Electrode
  Name: Electrode
  Type: STL Central_Electrode Fit
  Fab: 8.00000E-01 3.00000E-01
  Surface Region SolutionVolume
END

ENDFILE
```

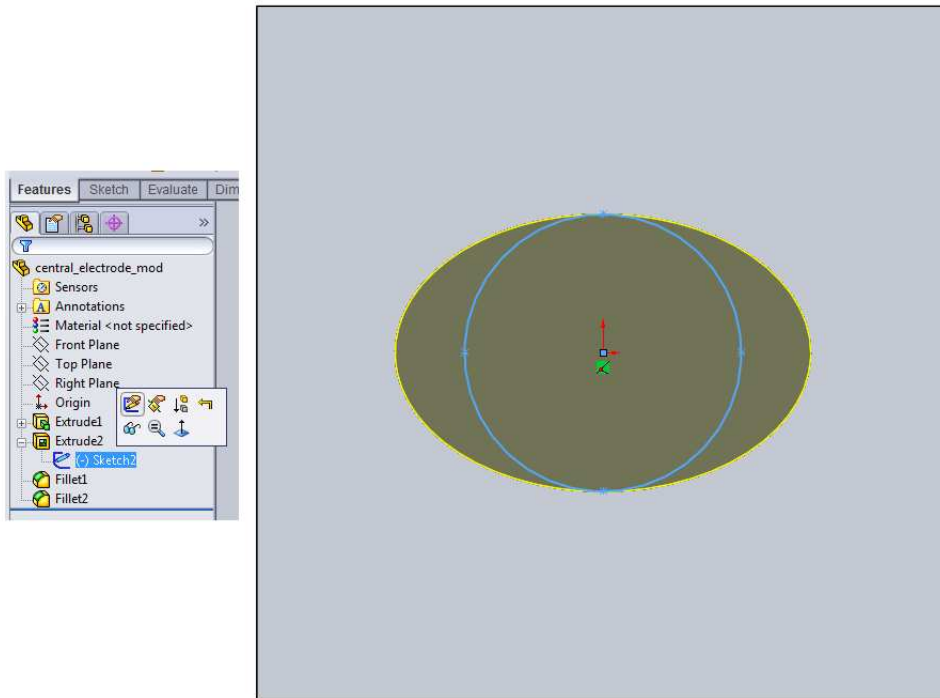

Figure 11: Modify the lens plate by editing the sketch that defines *Extrude2* (aperture).

The final issue for a simulation run to optimize beam dynamics is how to use the baseline part to create a series of lens plates with different aspect ratios R_y/R_x . It is easy to make changes in the **SolidWorks** model to create a set of STL files. Load `central_electrode.sldprt` and save it under a different name. Set the *View orientation* to **Front**. Check the *Features* list on the left-hand side (Fig. 11). The feature *Extrude2* represents the aperture and *Sketch2* defines its shape. Left-click on *Sketch2* and choose *Edit sketch*. Use the mouse to highlight the elliptical edge in the display. Its parameters appear in the information box on the left-hand side. For a test, change R_x to 10.0 mm to make a circular hole. Click the green check symbol to accept the sketch and then click *Exit sketch*. When you exit the sketch mode, the aperture and its dependencies (such as the fillets) are updated.