



## **Tutorial: Trak design of an electron injector for a coupled-cavity linear accelerator**

Stanley Humphries, Copyright 2010

### **Field Precision**

PO Box 13595, Albuquerque, NM 87192 U.S.A.

Telephone: +1-505-220-3975

Fax: +1-617-752-9077

E mail: [techinfo@fieldp.com](mailto:techinfo@fieldp.com)

Internet: <http://www.fieldp.com>

This tutorial describes the design of an electron injector for a coupled cavity linear accelerator. Figure 1 shows the injection port and initial stages of the accelerator. The radius of the beam port between accelerating cavities is 0.095" (2.41 mm). The machine has an average gradient of 10 MV/m at 90° phase. The gun should have a fixed accelerating voltage of 14 kV. At present, details of the electron capture process in the first gaps of the linac are unknown. In normal operation, the peak bunch current of the output beam is about 80 mA. To be conservative and leave room for future changes in requirements, I assumed that the gun should be able to deliver up to 300.0 mA.

I adopted the following practical goals for the gun design:

- The required source current density should be low ( $\leq 1.0 \text{ A/cm}^2$ ) to ensure a long lifetime for the dispenser cathode.
- The peak electric field should be low ( $\leq 100 \text{ kV/cm}$ ) to avoid the possibility of breakdown.
- The assembly should be about the same size as a Litton M592 gun and use the same power and control circuitry.
- Parts should be simple and relatively inexpensive to fabricate.
- The gun should produce a beam inside the accelerator having a radius and envelope angle that ensures complete capture over a reasonable range of accelerating phase.

The low perveance of the gun ( $\leq 0.181 \mu\text{perv}$ ) gives some design latitude. It would be simple to design a system matched at a single operating point. The challenge in this design is that the gun must provide an adequate beam over a range of operating current and linac capture phase.

My original hope was that it might be possible to substitute a control electrode with an aperture for the grid. I abandoned this idea for two reasons:

- The electrode voltage difference between suppression of electron flow and full current would be high ( $\gg 100 \text{ V}$ ).
- The electric field upstream from the control aperture must be smaller than the accelerating field downstream, creating a focusing aperture lens. The field difference would be higher for lower currents, resulting in increased focusing. The effect is the opposite of the desired behavior (increased focusing with higher current).

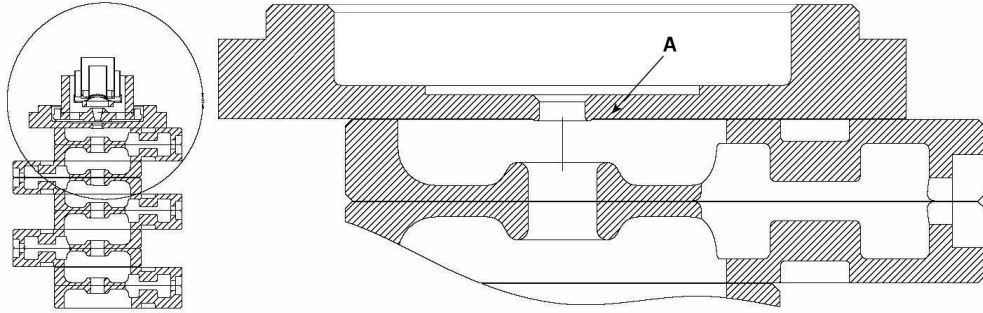

Figure 1: Entrance section of the coupled-cavity linear accelerator. Diameter of acceleration cavities: 0.900". Diameter of transport tubes: 0.190".

The implication is that a grid is unavoidable in a gun with variable current at a fixed voltage.

A complete design for a gridded electron gun must address two regions: 1) the cathode-grid gap, including the effects of field penetration through grid openings and 2) the main acceleration region. The first task requires a knowledge of the microscopic grid geometry that is currently unavailable. The task could be handled by the three-dimensional **OmniTrak** code. This tutorial is limited to the second task. Although the effort is primarily concerned with beam optics, I have made some effort to ensure a practical mechanical design that fits in the allowed space shown in Fig. 1

The gun design involved extended trial-and-error – this tutorial concentrates on the final configuration. Figure 2 shows a scale drawing of the electron gun mounted to the accelerator. The calculation begins at the surface of the control grid (left-hand boundary) under the assumption that the surface provides a uniform, controlled current density of low-energy electrons over a circular cross section. I used a planar cathode and grid for ease of fabrication and alignment. The cathode diameter (active area of grid) is 0.250", the same as the M592 gun. The diameter ensures that the cathode current density is  $\leq 1.0 \text{ A/cm}^2$ . The extension marked *C* in Fig. 2 provides electrostatic focusing to compress the beam to a diameter  $\ll 0.125$ " for injection into the accelerator. The extension also shields the grid surface from the strong electric field of the 14.0 kV acceleration gap. An 80 mA beam reaches a narrow waist within the anode aperture and is in expansion when it reaches the strong aperture lens at the accelerator entrance. The lens effect reduces the beam envelope angle approximately to zero when the accelerator field is 10 MV/m (90° phase).

I performed a series of studies to document the gun behavior at different levels of beam current and accelerator phase. Figure 3 shows the beam profile in the gun region at low and high beam current at an accelerator phase of

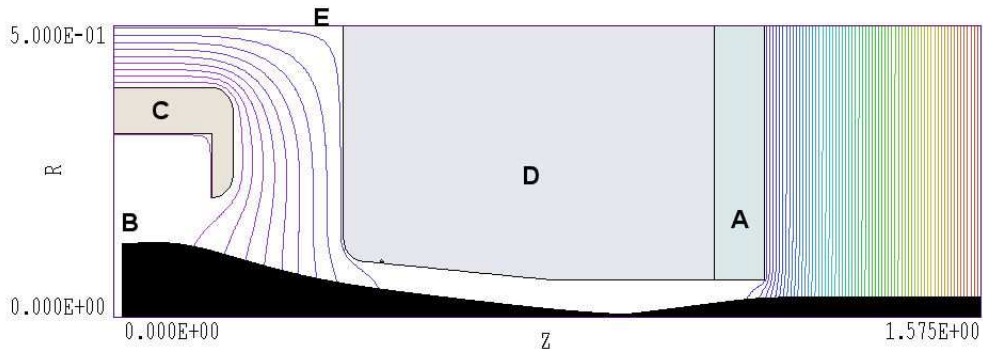

Figure 2: Electron gun concept, showing equipotential lines and electron orbits for  $I_b = 80.0$  mA, accelerator phase  $90^\circ$ . *A*) Accelerator entrance flange and aperture (see Fig. 1). *B*) Control grid surface. *C*) Grid support extension. *D*) Anode. *E*) Vacuum chamber inner wall. (Dimensions in inches.)

Table 1: Envelope radius and angle at 5.0 cm as a function of beam current and accelerator phase. (Port radius: 2.41 mm)

Current (mA)	Phase (deg)	R (mm)	R' (mrad)	Rf (mm)
75.0	45.0	1.43	8.00	2.66
	90.0	1.00	3.75	1.58
300.0	45.0	1.40	17.30	4.06
	90.0	1.21	15.00	3.52

$90^\circ$ . Space charge forces are stronger at higher current, so the beam does not reach a waist before entering the accelerator. The aperture lens focuses the narrow beam through a waist in the accelerator; therefore, the beam envelope is in expansion at large distance. To understand the implications, I increased the length of the simulation, with an accelerator region that extended 5.0 cm with uniform field  $E_z = 10.0$  MV/m. The field replicates that experienced by an electron at  $\sim 90^\circ$  phase neglecting transverse RF electric and magnetic fields in the machine. Figure 4 shows beam profiles at 75.0, 150.0 and 300.0 mA.

I also made calculations at an accelerator phase of  $45.0^\circ$  (7.07 MV/m). Here, the focusing affect of the entrance aperture is reduced. Table 1 summarizes beam envelope properties at a position 5.0 cm downstream from the accelerator entrance. To understand the implications, I also made calculations of single-particle electron orbits in a uniform accelerating field of 10.0 MV/m. Electrons with initial energy 0.5 MeV accelerated to 5.0 MeV over

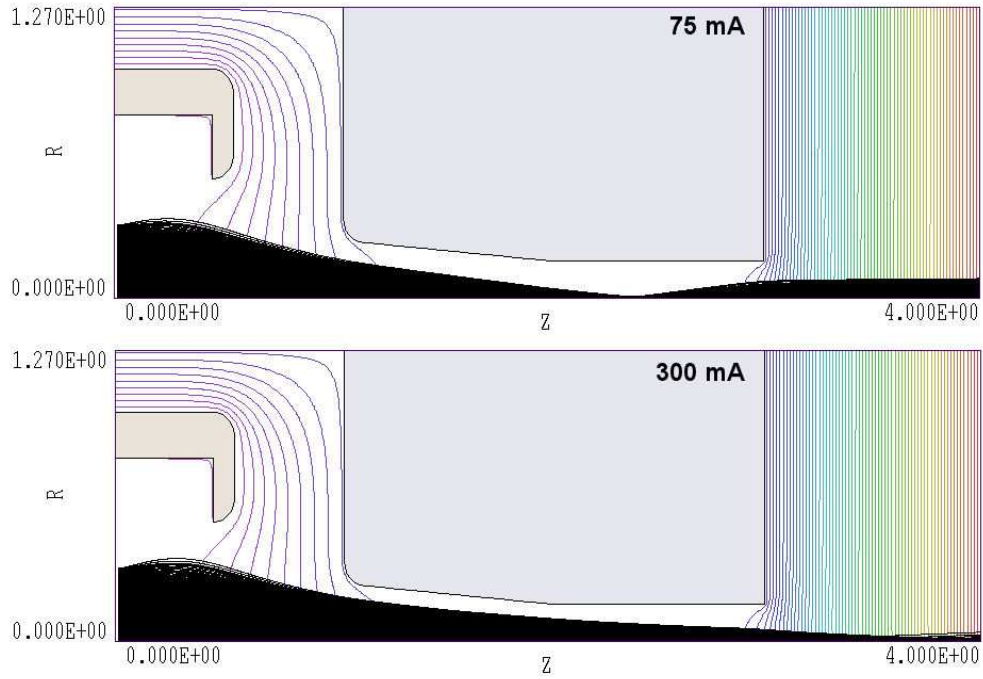

Figure 3: Beam profile at two current levels, accelerator phase  $90^\circ$ . Top: 75.0 mA. Bottom: 300.0 mA. (Dimensions in cm.)

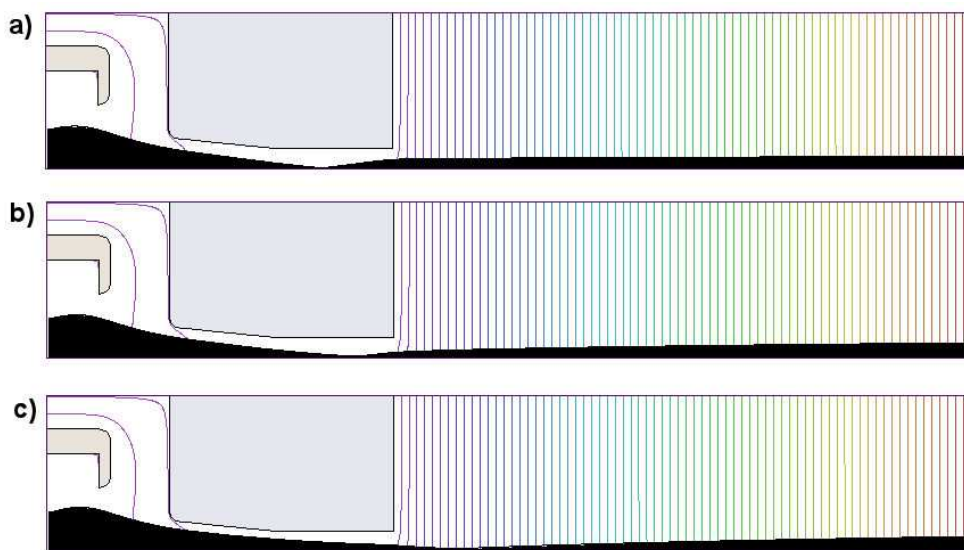

Figure 4: Beam profiles at three current levels – extended accelerator propagation region for electrons at  $90^\circ$  phase. a) 75.0 mA. b) 150.0 mA. c) 300.0 mA. (Dimensions in cm.)

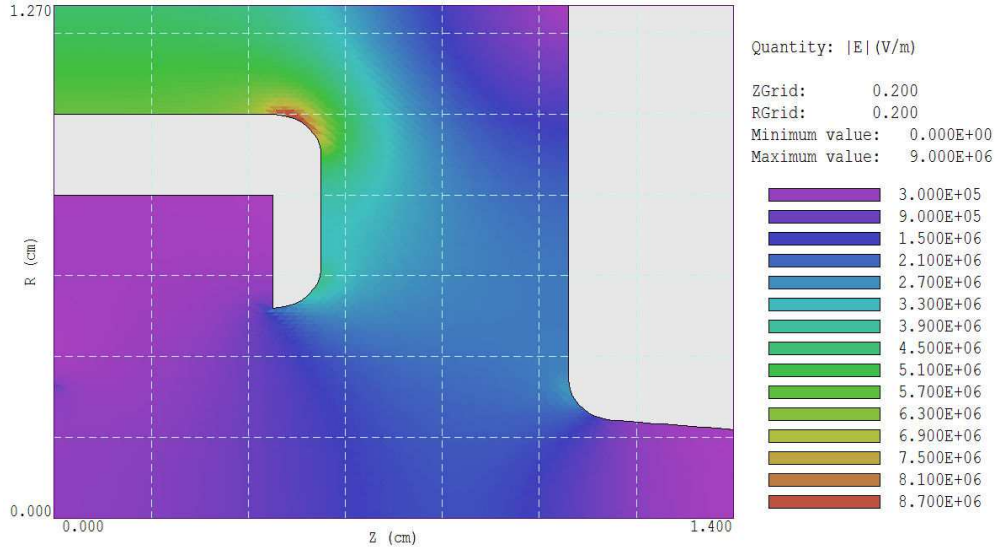

Figure 5: Map of  $|\mathbf{E}|$  in the electron gun. (Dimensions in cm.)

a length 45.0 cm. The electron displacement as a function of injection angle was:

$$\Delta r = 0.154 \text{ mm/mrad.} \quad (1)$$

Values from Table 1 were used to project the envelope radius to 50.0 cm. The values are listed in the final column of the table. In the optimum case (75.0 mA with 10.0 MV/m gradient), the final beam radius is less than the accelerator beam port radius. The implication is that the full current should be captured and transported in the machine. The beam radius is slightly larger than the port radius at  $\phi = 45.0^\circ$ ; therefore, this phase represents a lower limit for electron capture without loss. At 300 mA, the beam radius is significantly larger than the port. More than half the beam current will be lost. In this light, the results of Report 01 suggest that there is significant current loss in the present configuration with the M592 gun. To conclude, Fig. 5 shows a plot of  $|\mathbf{E}|$  in the electron gun. The peak field is significantly smaller than that in the Litton gun.